

## TOWER 300

### Stainless Steel Dispensing Towers



7" Single Valve



7" two Valve



18" Stainless Steel



23" Stainless Steel

The TOWER 300 is designed using the highest quality materials and state-of-the-art technology providing our customers with consistent drink quality.

- Island base dispensing towers
- Stainless steel construction
- Designed for easy installation
- Optional merchandiser and marquee available on the 18" and 23" towers
- All valves can be serviced independently





# Tower 300

## S P E C I F I C A T I O N S

### 7" SINGLE VALVE

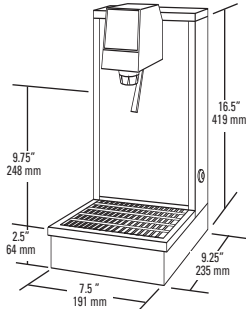

#### DIMENSIONS

Width: 7.5" (191 mm)  
Depth: 9.25" (235 mm)  
Height: 16.5" (419 mm)

#### WEIGHT

Shipping: 15 lbs (7 kg)

#### ELECTRICAL

24VAC/60Hz

#### VALVES

LEV® and other valves available upon request

#### KEY LOCK SWITCH

#### POWER SUPPLY INCLUDED

### 7" TWO VALVE

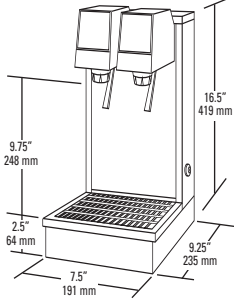

#### DIMENSIONS

Width: 7.5" (191 mm)  
Depth: 9.25" (235 mm)  
Height: 16.5" (419 mm)

#### WEIGHT

Shipping: 15 lbs (7 kg)

#### ELECTRICAL

24VAC/60Hz

#### VALVES

LEV® and other valves available upon request

#### KEY LOCK SWITCH

#### POWER SUPPLY INCLUDED

### 18" FIVE VALVE

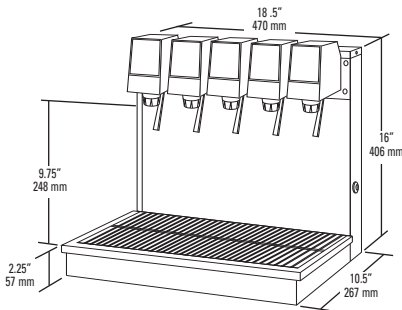

#### DIMENSIONS

Width: 18.5" (470 mm)  
Depth: 10.5" (267 mm)  
Height: 16" (406 mm)

#### WEIGHT

Shipping: 37 lbs (17 kg)

#### ELECTRICAL

24VAC/60Hz

#### VALVES

LEV® and other valves available upon request

#### KEY LOCK SWITCH

#### POWER SUPPLY INCLUDED

### 23" SIX VALVE

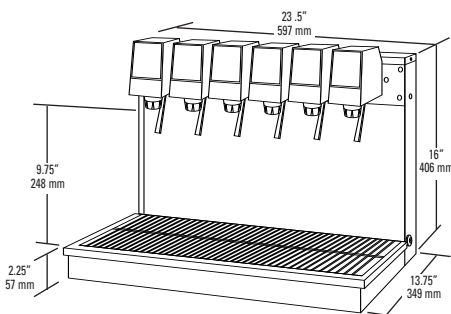

#### DIMENSIONS

Width: 23.5" (597 mm)  
Depth: 13.75" (349 mm)  
Height: 16" (406 mm)

#### WEIGHT

Shipping: 42 lbs (19.05 kg)

#### ELECTRICAL

24VAC/60Hz

#### VALVES

LEV® and other valves available upon request

#### KEY LOCK SWITCH

#### POWER SUPPLY INCLUDED

**Warranty:** For warranty specifics by product, contact your Lancer Sales Representatives.

Equipment design and/or specifications may change without notice.

CORPORATE OFFICE 6655 Lancer Blvd - San Antonio, TX 78219  
210-310-7000 - 1-800-729-1500 - FAX 210-310-7250 - www.lancercorp.com

"Lancer" is the registered trademark of Lancer © 2007 by Lancer, all rights reserved.

TOWER 300 Spec Sheet 08/07