



Shrouded cabinet with optional lighted marquee

CED 9000 Dispenser

The CED 9000 is designed using the highest quality materials and state-of-the-art technology providing our customers with consistent drink quality.

- Stainless steel cabinet, water bath, product lines, and drip tray assembly; removable refrigeration deck
- Available with 5 or 6 post-mix dispensing valves
- All valves can be serviced independently
- Insulation is CFC-free structural foam
- Flex manifold configuration for multiple non-carbonated drinks
- Consistent cold carbonation for improved drink quality
- Syrup and water are accessible from the rear of cabinet
- Full wrap around merchandising
- Shrouded cabinet with illuminated graphics available
- Fully louvered top provides air circulation for more efficient operation



ETL CERTIFIED TO UL STD 471 AND
CAN/CSA STD 22.2 NO. 120

LANCER®

CED 9000

OPTIONS

Standard Cabinet



Shrouded Cabinet with Standard Decal



COMPRESSOR

1/3 hp

MOTORS

Agitator: 25 w
Condenser fan: 9 w

ICE BANK CONTROL

Lancer Electronic Ice Bank Control

SPECIFICATIONS

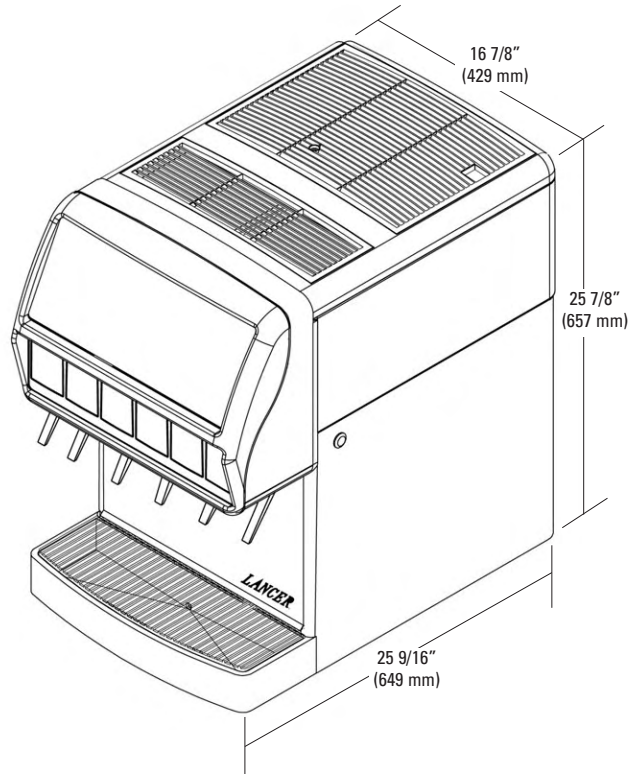

DIMENSIONS

Width: 16.875 in (429 mm)
Depth: 25.563 in (649 mm)
Height: 35.875 in (657 mm)

ELECTRICAL

115VAC/60Hz, 4.5AMPs
230VAC/50Hz, 4.5AMPs

WEIGHT

Empty: 146 lbs (66.2 kg)
Operating: 220 lbs 99.8 kg)
Shipping: 160 lbs (72.6 kg)

ICE

Capacity: 25-28 lbs
(11.3-12.7 kg)

FITTINGS

Soda inlets: 3/8" male barb
Syrup inlets: 3/8" male barb

VALVES

LEV® and other valves
available upon request

FLEX MANIFOLD CONFIGURATION

5 valve 2-2-1
6 valve 3-2-1

KEY LOCK SWITCH

DRAW PERFORMANCE

Number of Drinks Below 40°F

75°F (24°C) Ambient Temperature

125 drinks; 12oz. / 2 drinks per minute
97 drinks; 12oz. / 4 drinks per minute

90°F (32°C) Ambient Temperature

115 drinks; 12oz. / 2 drinks per minute
92 drinks; 12oz. / 4 drinks per minute

Warranty: For warranty specifics by product, contact your Lancer Sales Representatives.

CORPORATE OFFICE 6655 Lancer Blvd - San Antonio, TX 78219
210-310-7000 - 1-800-729-1500 - FAX 210-310-7250 - www.lancercorp.com

Equipment design and/or specifications may change without notice.

"Lancer" is the registered trademark of Lancer © 2007 by Lancer, all rights reserved.

CED 9000 CC Spec Sheet 09/07