

LANCER®

CED 500

Standard Performance Dispenser



The CED 500 is designed using the highest quality materials and state-of-the-art technology providing our customers with consistent drink quality.

- Stainless steel cabinet, water bath, product lines and drip tray assembly
- Occupies a small area of counter space, only 10 3/8" wide. Compare with conventional dispenser
- Available with 4 post-mix dispensing valves
- All valves can be serviced independently
- Insulation is CFC-free, 0 GWP, structural foam
- Removable refrigeration deck. All installation from front of unit
- Leg kit included
- CFC-free, R134A Refrigerant
- 1/4 hp, 17 lb ice bank, flooded manifold



ETL CERTIFIED TO UL STD 471 AND
CAN/CSA STD 22.2 NO. 120



CED 500 Standard Performance

OPTIONS

Lighted Marquee



SPECIFICATIONS

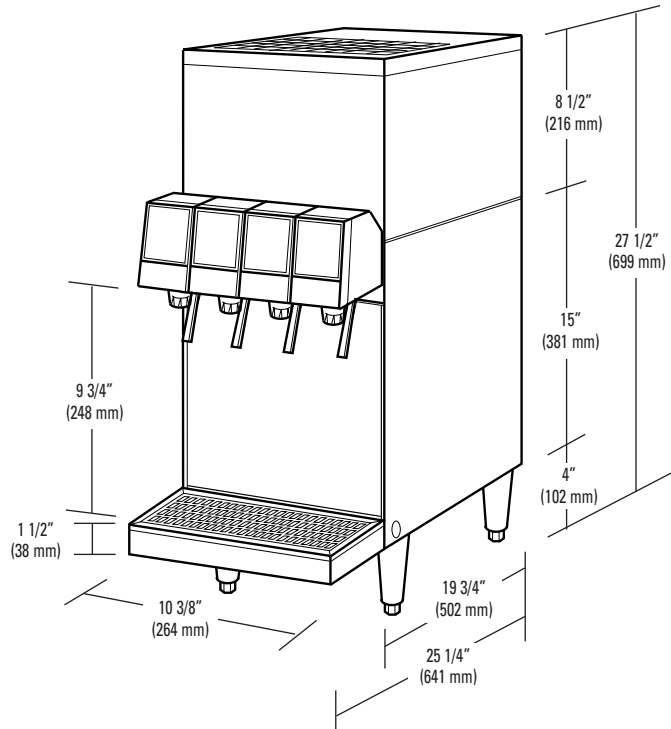

COMPRESSOR

1/4 hp

MOTORS

Agitator: 15 w
Condenser fan: 9 w

ICE BANK CONTROL

Lancer Electronic Ice Bank Control

TRANSFORMER

24 VAC Secondary

WATER

Capacity: 5 gallons

DIMENSIONS

Width: 10.375 in (264 mm)
Depth: 25.25 in (641 mm)
Height: 27.5 in (699 mm)

ELECTRICAL

115VAC/60Hz, 7AMPs
230VAC/50Hz, 3.3AMPs

WEIGHT

Empty: 89 lbs (40.4 kg)
Operating: 131 lbs (59 kg)
Shipping: 108 lbs (49 kg)

ICE

Capacity: 17 lbs (7.7 kg)

FITTINGS

Soda inlets: 3/8" male barb
Syrup inlets: 3/8" male barb

VALVES

LEV® and other valves available upon request

KEY LOCK SWITCH

DRAW PERFORMANCE

Number of Drinks Below 40°F

75°F (24°C) Ambient Temperature

161 drinks; 12oz. / 2 drinks per minute

Warranty: For warranty specifics by product, contact your Lancer Sales Representatives.

CORPORATE OFFICE 6655 Lancer Blvd - San Antonio, TX 78219
210-310-7000 - 1-800-729-1500 - FAX 210-310-7250 - www.lancercorp.com